

Read this instruction carefully. See hardware and furniture part list for guidance. Be sure all parts are complete, before you assemble. Place all wooden furniture parts on a clean and flat soft surface to prevent from being scratched. Follow the figure to start assembling.

**CAUTIONS :** 1. Do not FULLY - TIGHTEN the nut or nut bolt until all nut or bolt is ready assembled.  
 2. Do not OVER - TIGHTEN the nut or bolt to avoid causing damages to the thread.  
 3. Keep all hardware parts out of reach of children.

**NOTE :** THE LIST AND QUANTITY SHOWN ARE FOR 1 UNIT ASSEMBLY.

Tool needed : Screwdriver (not provided).

PART LIST		
ITEM	DESCRIPTION	QTY
A	HEADBOARD	1 PC
B	FOOTBOARD	1 PC
C	SIDE RAIL	2 PCS
D	CENTER RAIL	1 PC
E	CENTER SUPPORT LEG	3 PCS
F	HEADBOARD SUPPORT WOOD	2 PCS
G	FOOTBOARD SUPPORT WOOD	1 PC
H	BED LEG	4 PCS
I	BED SLAT	24 PCS
J	CENTER SUPPORT	2 PCS

HARDWARE LIST		
ITEM	DESCRIPTION	QTY
1	JCBC BOLT M6 x 40mm	4 PCS
2	JCBB BOLT M8 x 40mm	7 PCS
3	M8 FLAT WASHER	7 PCS
4	M8 SPRING WASHER	7 PCS
5	WOOD SCREW M3.5 x 16mm	8 PCS
6	BED SIDE FITTER	24 PCS
7	BED CENTER FITTER	12 PCS
8	M4 ALLEN KEY (BALL SHAPE)	1 PC
9	M5 ALLEN KEY (BALL SHAPE)	1 PC
10	WOOD SCREW M4 X 20mm	2 PCS

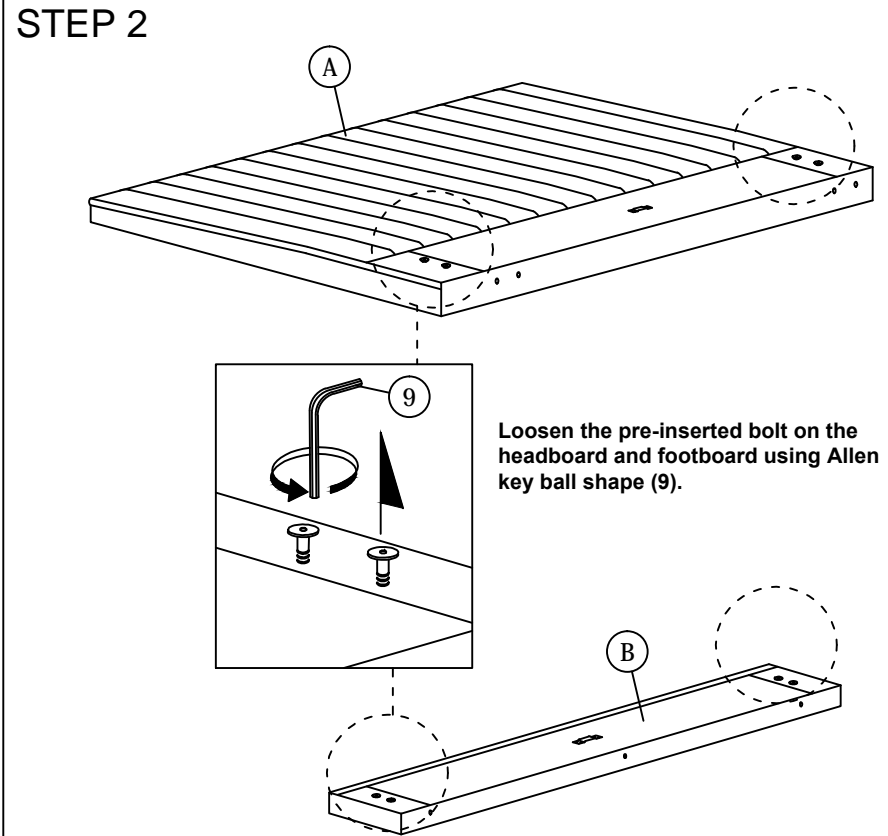
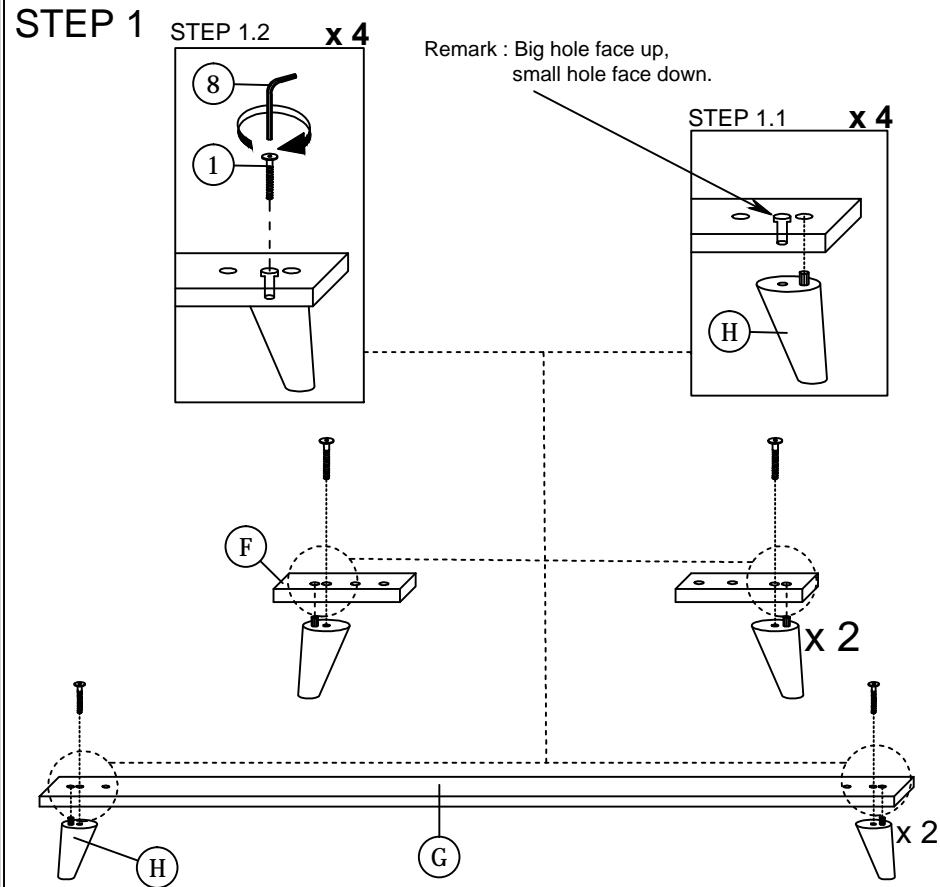

# ASSEMBLY INSTRUCTIONS

STEP 3

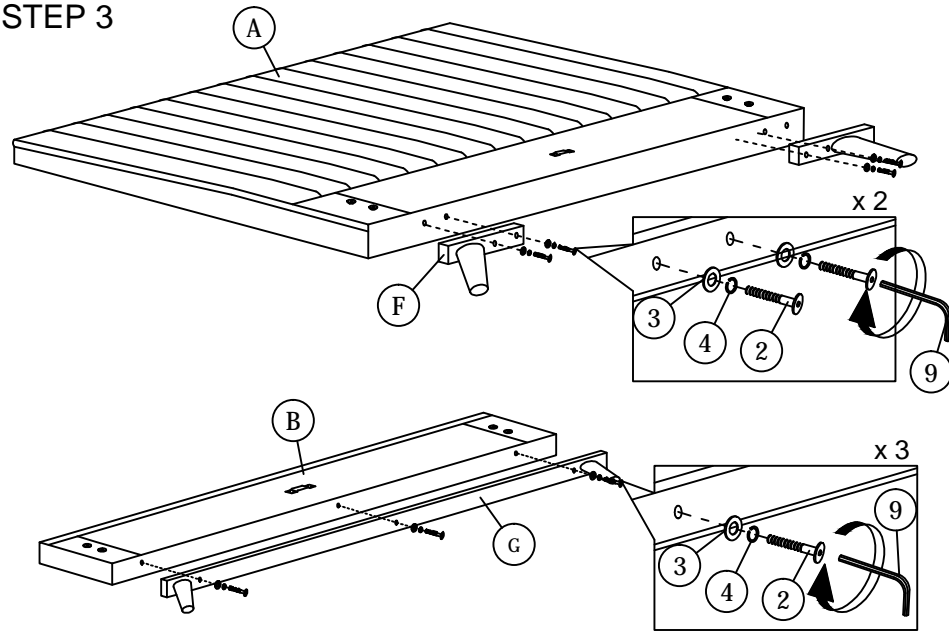

STEP 4

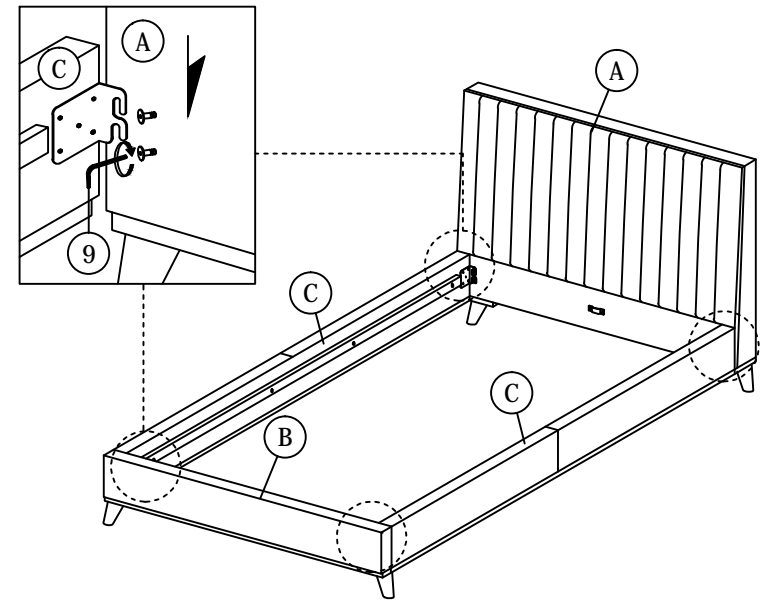

STEP 5

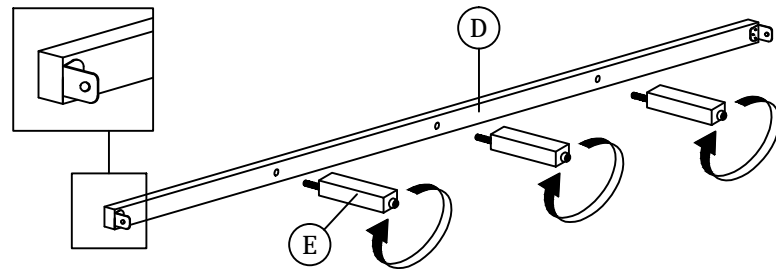

STEP 6

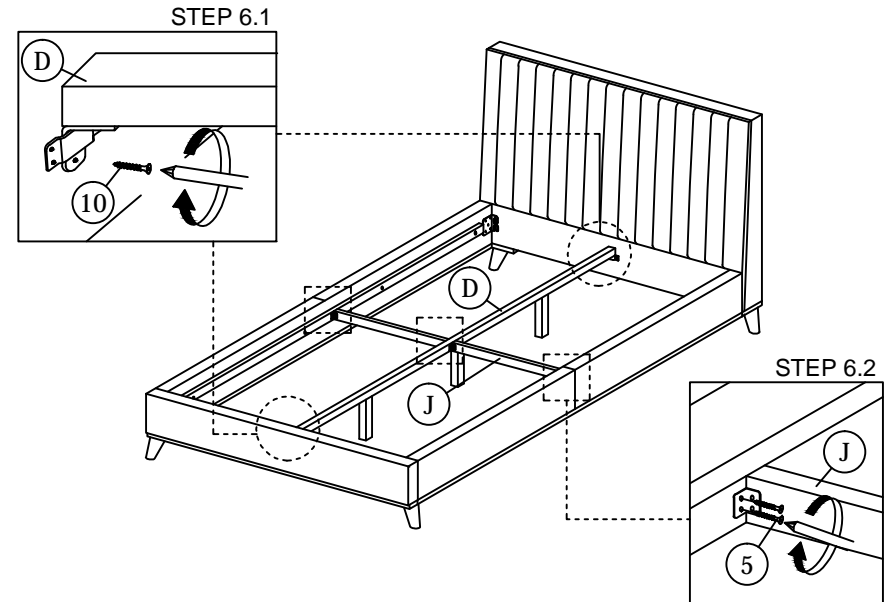

# ASSEMBLY INSTRUCTIONS

## STEP 7

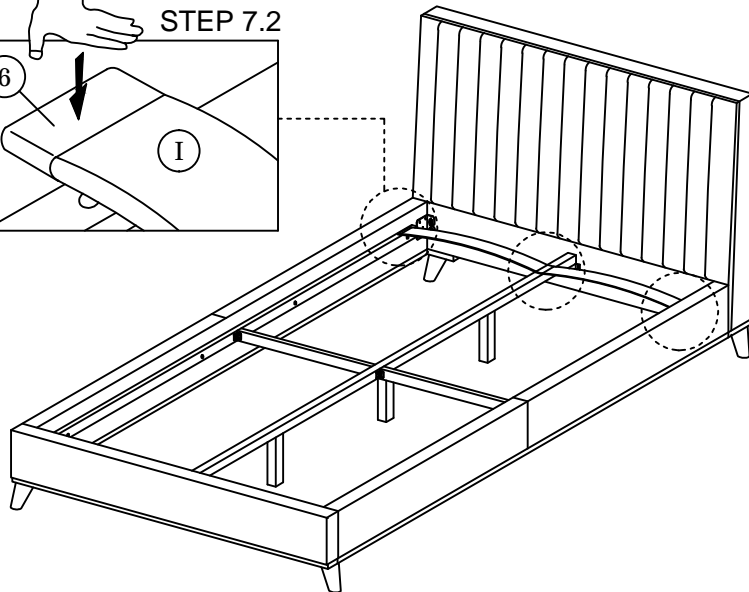
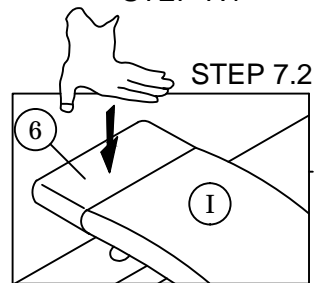
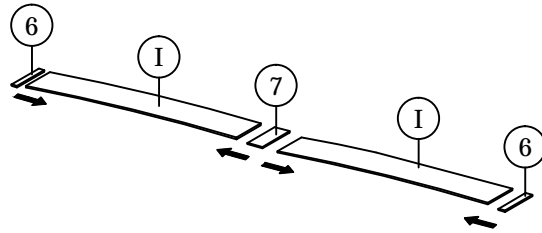
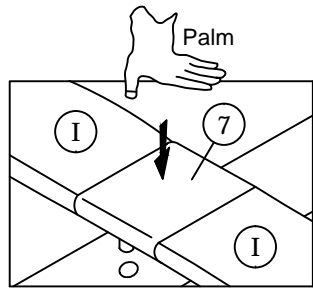

## STEP 8

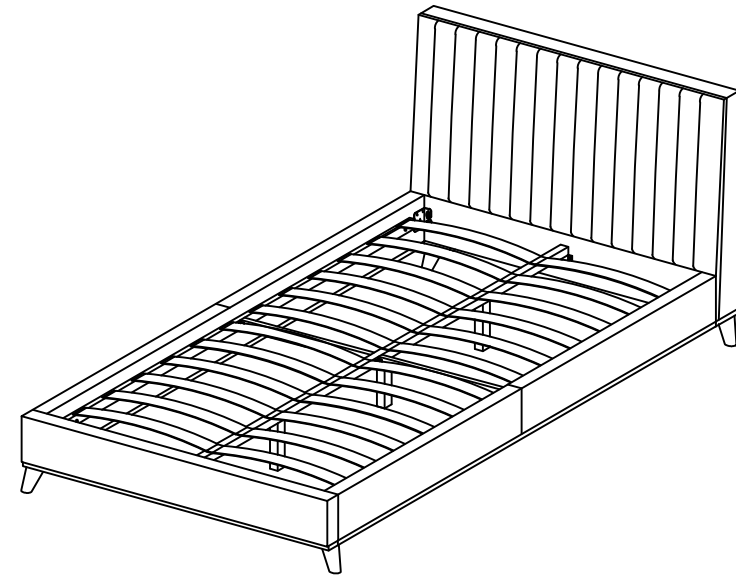

\* When moving the bed position, the center support legs must be adjust to be straight to avoid any broken problem.